

# "ZL" Series Butt Splicers for Light Board Applications

## Standard Features:

- ❑ Zero-Gap Butt Splice Guarantees No Overlap Splicing
- ❑ Shaftless Turret Design for Full Width Roll Support
- ❑ Easy Roll Loading from Floor
- ❑ Easy, Single-Method Splice Preparation Assures Reliable Splicing
- ❑ Heavy-Duty Construction
- ❑ Fully Automatic Splice Cycle
- ❑ Distributed Computer Control System
- ❑ Automatic Microprocessor Control
- ❑ System Diagnostics
- ❑ Automatic Roll Sidelay
- ❑ Bi-Directional Unwind Capability
- ❑ Two-Sided Tape Application for Maximum Splice Strength

## Specifications:

- ❑ Web Width: Up to 50 Inch (1270 mm)
- ❑ Splice Speed: Up to 1000 FPM (304 MPM)
- ❑ Roll Diameter: 72 Inch (1828 mm)
- ❑ Material: Up to 24 pt. Paperboard

## Options:

- ❑ In-Register Splice System for Pre-Printed or Pre-Punched Webs
- ❑ Automatic Rolling Element Decurler

14357 Commercial Parkway  
South Beloit, IL 61080  
Phone: 815-624-8989  
Fax: 815-624-4223  
Internet: [www.keenetechnology.com](http://www.keenetechnology.com)  
E-mail: [info@keenetechnology.com](mailto:info@keenetechnology.com)



Shown: ZL 2272-05, Two Piece Butt Splicer for Light Board



Shown: ZL 5072-05, Three Piece Butt Splicer for Light Board

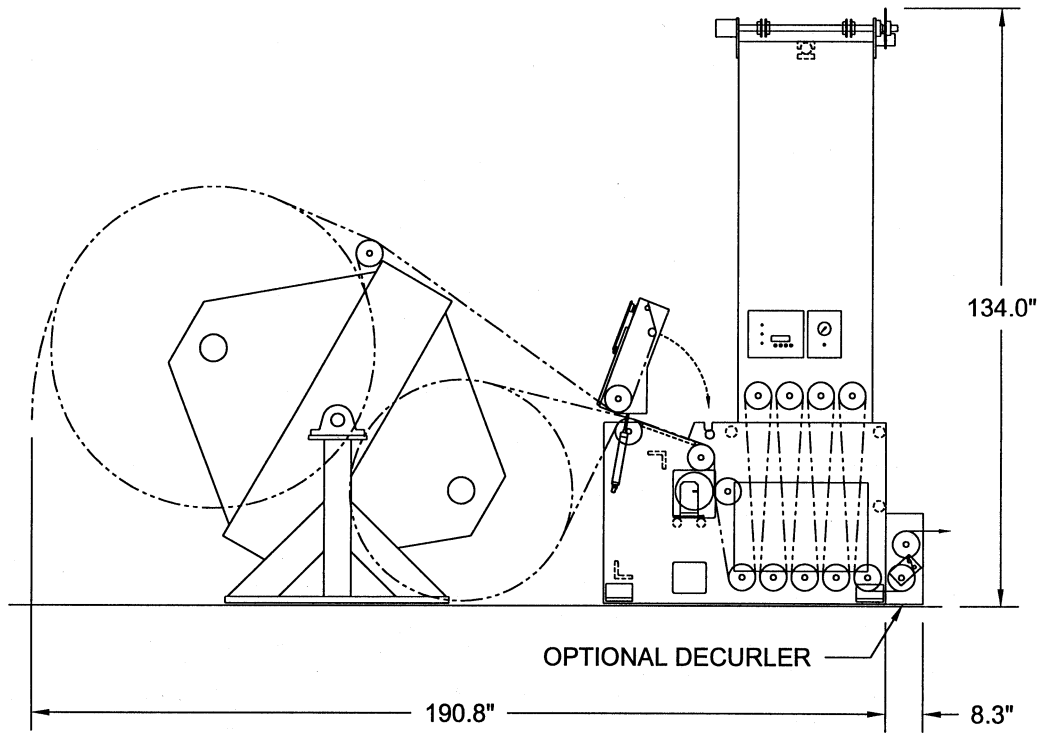

MODEL ZL2272-05

DIMENSIONS SUBJECT TO CHANGE WITHOUT NOTICE

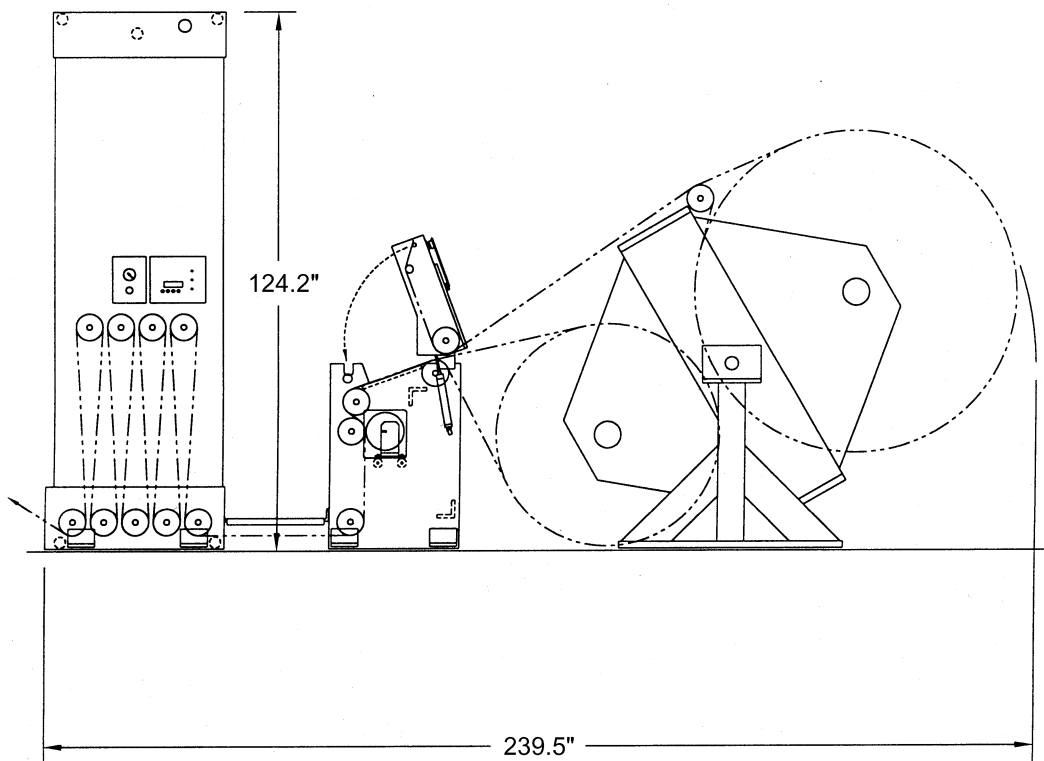

MODEL ZL5072-05

DIMENSIONS SUBJECT TO CHANGE WITHOUT NOTICE