

"PA" Series Packaging Splicer



Shown: Model PA 2024-05 Packaging Splicer

14357 Commercial Parkway
South Beloit, IL 61080
Phone: 815-624-8989
Fax: 815-624-4223
Internet: www.keenetechnology.com
E-mail: info@keenetechnology.com

**Permits Non-Stop
Package Production**

**Increases Productivity
and Reduces Waste**

**In-Register Splicing of
Pre-Printed Webs (Optional)**

**Looking for a way to increase
your profits? Let a KTI "PA" Series
Splicer automatically splice the end
of the expiring roll to the leading
edge of the new roll of material.
This eliminates the need to stop your
production line to change rolls.**

Standard Features:

- Splice Made at Zero Speed
- Minimum Tail Splicehead
- Bi-Directional Unwind Capabilities
- Pneumatic Cantilevered Spindles
- Direct Roll Loading
- Automatic Microprocessor Control
- System Diagnostics
- Automatic Press Stop (No Prep or Web Break)
- Handles a Variety of Materials

Specifications:

- Web Width: Up to 26 Inch (660 mm)
- Splice Speed: Up to 1000 FPM (304 MPM)
- Roll Diameter: Up to 24 Inch (609 mm)
- Roll Weight: Up to 350 LBS (158 kg)

Options:

- Automatic Spindle Inflate/Deflate
- Spiral Grooved Idler Rollers
- Roll Loading Cart

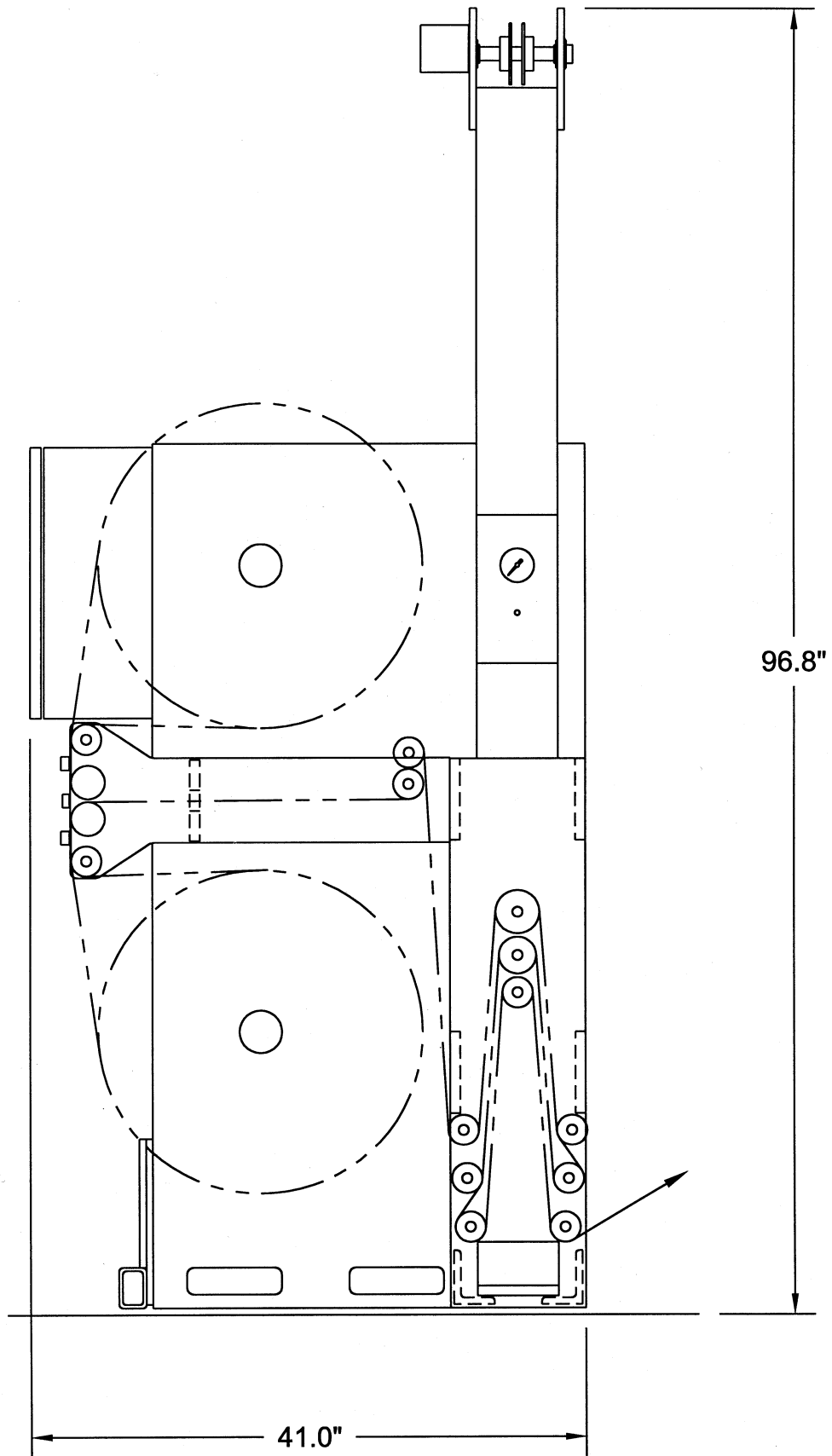

MODEL PA1624-05

DIMENSIONS SUBJECT TO CHANGE WITHOUT NOTICE