

"MR" Series Multiple Spindle Turret Rewinder



Shown: MR 2024-05, Turret Rewind

14357 Commercial Parkway
South Beloit, IL 61080
Phone: 815-624-8989
Fax: 815-624-4223
Internet: www.keenotech.com
E-mail: info@keenotech.com

EKTI
Keene Technology, Inc.

Standard Features:

- 3 Spindle Configuration
- Cutting and Transfer at Zero Speed
- Integrated Festoon Allows Transfer at Full Line Speed
- AC Vector Drive
- 3 Inch Pneumatic Spindles
- Rugged Plate-Steel Construction
- Automatic Inflation/Deflation of Spindles
- Rewind to Footage Count or Roll Diameter
- Automatic Microprocessor Control
- Left- or Right-Hand Configurations

Specifications:

- Web Width: 16, 20, and 24 Inch (406, 508, and 609 mm)
- Splice Speed: Up to 1000 FPM (304 MPM)
- Rewound Roll Diameter: 24 Inches (609 mm)

Options:

- Automatic Web Gluing
- Finished Roll Eject Assist
- Cut Between Labels/Label Count
- Shear Cut Slitting
- Finished Roll Unloading Cart
- Casters
- Web Guide
- Bowed Spreader Roller
- Bowed Spreader Bar
- Pneumatic Spindles Available for Alternate Core Sizes
- Non-Stick Plasma Coated Idlers

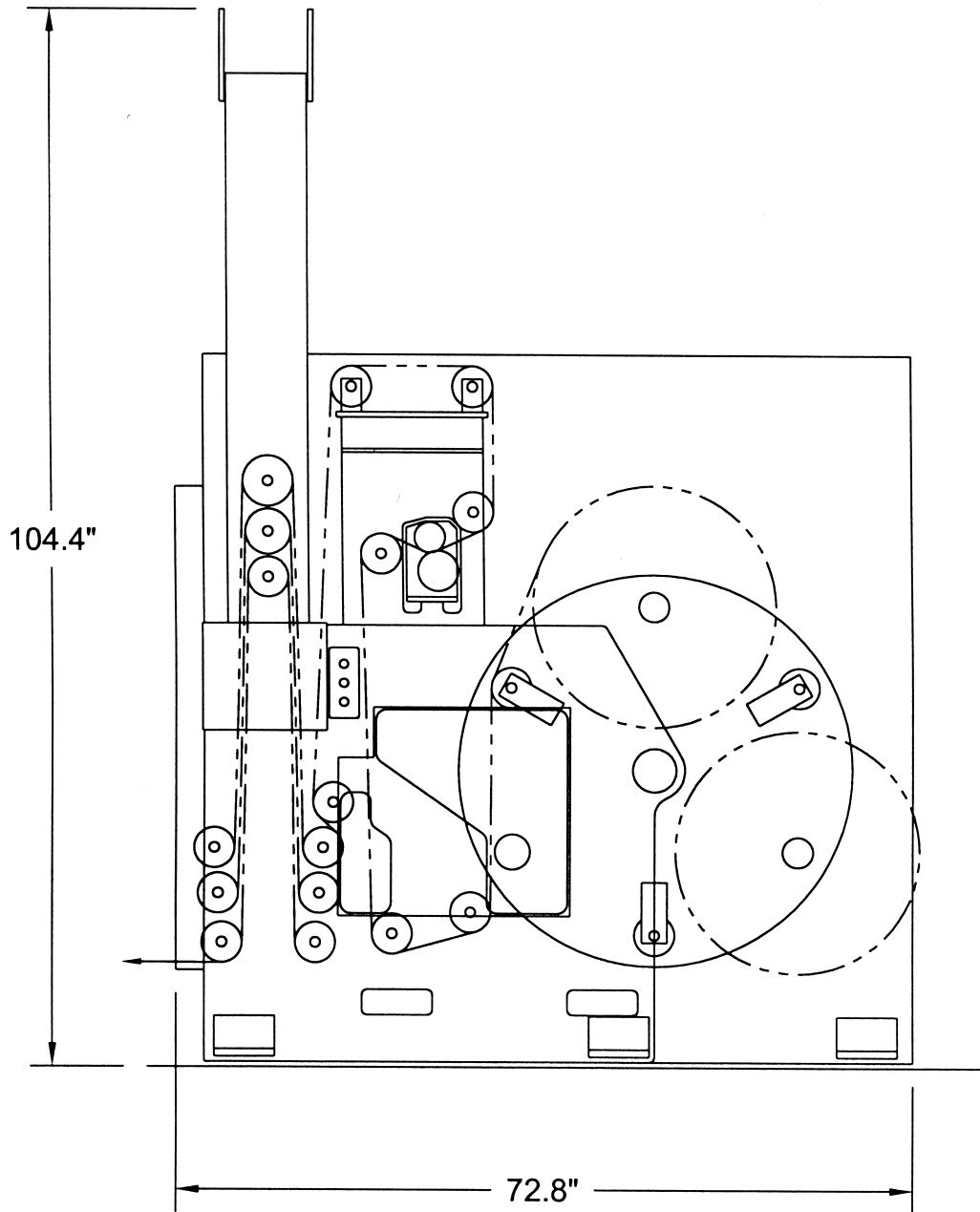

MODEL MR2024-05

DIMENSIONS SUBJECT TO CHANGE WITHOUT NOTICE