

"ZG" Series "Shaftless" Butt Splicers for Tag & Label

Standard Features:

- Zero-Gap Butt Splice Guarantees No Overlap Splicing
- Shaftless Turret Design for Full Width Roll Support
- Easy Roll Loading from Floor
- Easy, Single-Method Splice Preparation Assures Reliable Splicing
- Heavy-Duty Construction
- Fully Automatic Splice Cycle
- Automatic Microprocessor Control
- System Diagnostics
- Automatic Roll Sidelay
- Two-Sided Tape Application for Maximum Splice Strength
- Automatic Leading Edge Trim
- Automatic Tape Edge Trim
- Low Riding Festoon

Specifications:

- Web Width: 22 - 40 Inch (559 - 1016 mm)
- Splice Speed: Up to 1000 FPM (304 MPM)
- Roll Diameters: 40 or 50 Inch (1016 or 1270 mm)
- For up to 12 pt. Paperboard and Many Other Materials

Options:

- In-Register Splice System for Pre-Printed or Pre-Punched Webs
- Automatic Rolling Element Decurler

14357 Commercial Parkway
South Beloit, IL 61080
Phone: 815-624-8989
Fax: 815-624-4223
Internet: www.keenetech.com
E-mail: info@keenetech.com



Shown: ZG 2040-05, Butt Splicer for Tag and Label



Shown: ZG 2640-10, Butt Splicer for Tag and Label

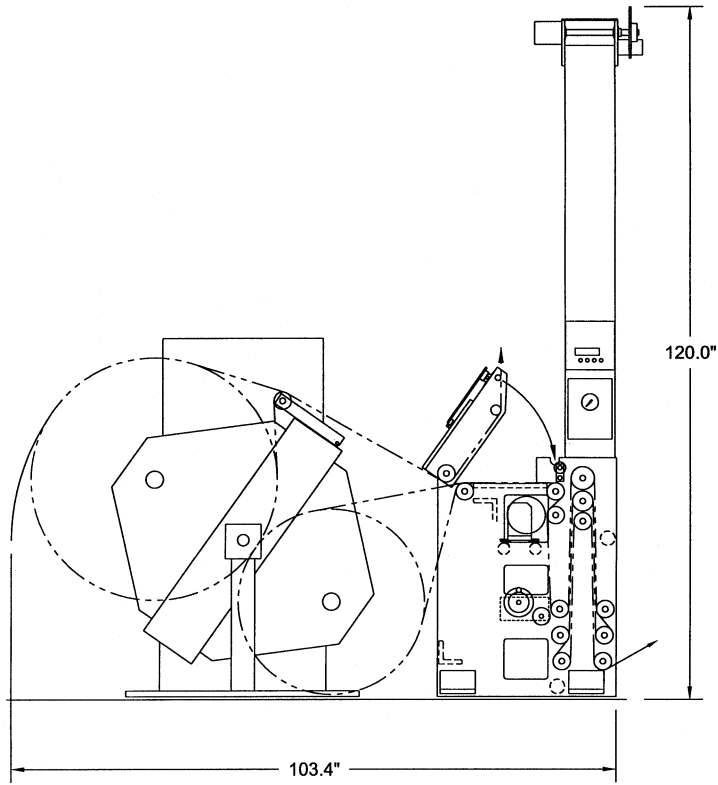

MODEL ZG2040-05

DIMENSIONS SUBJECT TO CHANGE WITHOUT NOTICE

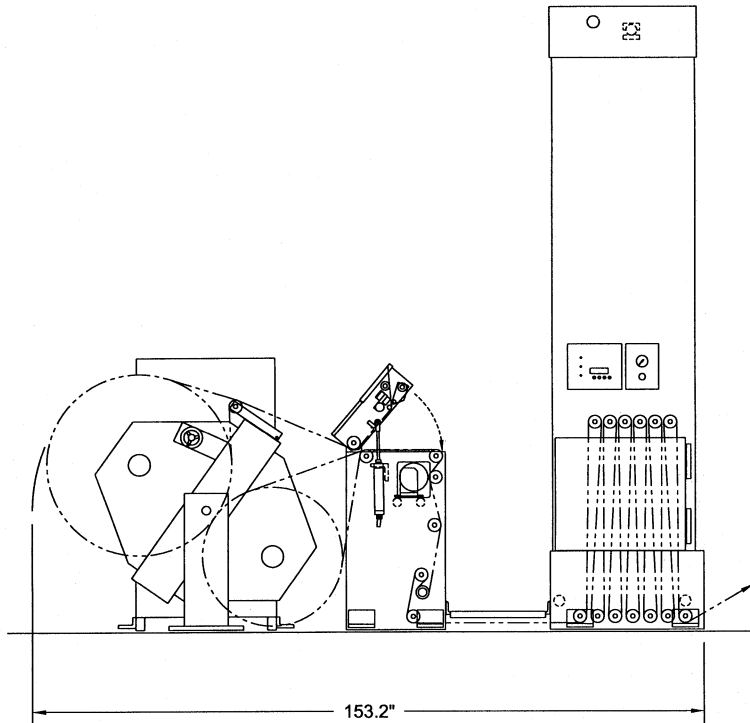

MODEL ZG2640-10

DIMENSIONS SUBJECT TO CHANGE WITHOUT NOTICE